

7700-48-B-1.7C-M-SD-A-X-DC-G_GEN5



The Sirius Capacitor Module (“Sirius”) is supercapacitor-based storage that uses supercapacitors as storage cells instead of chemical cells. Kilowatt Labs’ proprietary balancing, control and charge retention algorithms control the operation of the supercapacitor-based Modules, making Sirius a safe, efficient and effective alternative to chemical batteries wherever chemical batteries are deployed.

PERFORMANCE SPECIFICATIONS	
DC Energy	7700WH
DC Voltage (Nominal)	48V _{dc}
Technology	Supercapacitors
Type	Pouch Cells

CHARGE SPECIFICATIONS	
Maximum Charge Current	272A (1.7C)
Maximum Charge Voltage Range	44 V _{dc} - 57 V _{dc}

DISCHARGE SPECIFICATIONS	
Maximum Discharge Current	272A (1.7C)
Maximum Discharge Voltage Range	44 V _{dc} - 57 V _{dc}

ENVIRONMENTAL SPECIFICATIONS	
Cell Operating Temperature	-30°C to 80°C
Operating Humidity	Non-Condensing

SMART FEATURES	
Communication and Connectivity	WIFI + CANBUS + USB Serial + Bluetooth
Alarm	Buzzer alarm in the event of Over/under-Voltage, Over-Current, Over Temperature
Dry Contacts x4	Programmable

SIRIUS VIEW APP	
Module Monitoring	Total Voltage, Individual Cell Voltages, Current, Temperatures, Instantaneous Power, Circuit Breaker Status, SOC and Energy Consumed.

7700-48-B-1.7C-M-SD-A-X-DC-G_GEN5

MECHANICAL SPECIFICATIONS	
Dimensions (W x H x D) mm	520 x 350 x 790
Weight (Kg)	163
Module Casing Material	GI Powdered
Terminal Type	F08
Enclosure	IP20

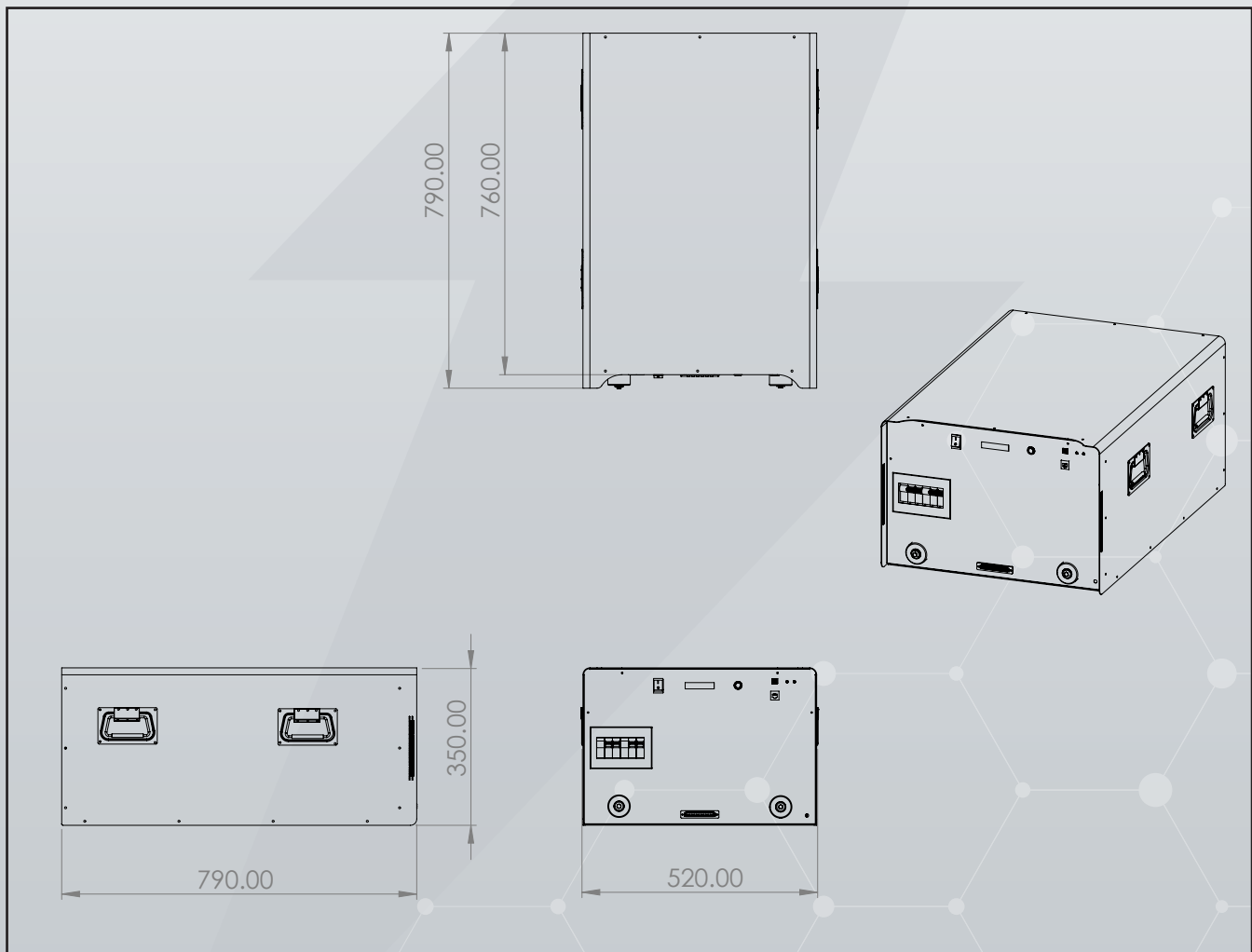

7700-48-B-1.7C-M-SD-A-X-DC-G_GEN5

SAFETY PERFORMANCE

Short Circuit Protection	10KA, Hardware Protection, Terminal Cut-off
Additional Safety	2x 125A 2P Mechanical Actuated Breaker
Over/under voltage	Hardware protection, Terminal Cut-off
Over Current	Hardware protection, Terminal Cut-off
Over temperature	Hardware protection, Terminal Cut-off

MODULE SERVICE LIFE

Projected Cycle Life	1 million cycles
Projected Calendar Life	45 years
Shelf Life	10 years
Warehousing	Can be stored at any SOC without affecting cycle life

COMPLIANCE INFORMATION

EN55032:2015, EN55024:2010,
EN61000-4-2:2009, EN61000
EN61000:2008+A2:2010

PRECAUTIONS

Alarm	In case of alarm, immediately rectify/attend to the cause of the alarm.
Physical Damage	In case the Module is physically damaged due to any event, do not install and energize the Module under any circumstances and contact your Reseller.
Short Circuit	Ensure precautions to prevent short-circuit under all circumstances.
Galvanic isolation	When connecting to external devices ensure that galvanic isolation does not exceed 1000V.
Series Connection	<ul style="list-style-type: none"> All Modules must be at 100% SOC before connecting in series. A maximum of 8 Modules with Module Combiner can be connected in series. Please consult your Reseller when connecting the Modules in series.
Parallel Connection	There is no limit on the number of Modules that can be connected in parallel.
Series-Parallel Connection	Modules cannot be connected in series-parallel combination under any circumstance.

7700-48-B-1.7C-M-SD-A-X-DC-G_GEN5

¹The temperature range indicates the range in which the supercapacitor cells can operate. The performance of the cells may vary if they are continuously operated outside a temperature range of -10°C to 55°C, and/or at C-rates higher than the maximum charge/discharge rate specified in this spec sheet. The operating temperature range of the module varies based on the application. If the module is to be operated continuously outside a temperature range of -10°C to 55°C, and/or at C-rates higher than the maximum charge/discharge rate specified in the spec sheet, please consult Kilowatt Labs or its Reseller prior to deploying.

² Warranty conditions will apply. Please consult your Reseller or www.kilowattlabs.com/warranty for warranty conditions applicable to your region.

³ Projected life of supercapacitor cells. Cycle life will vary if cycled more than 4 times a day.

⁴ Additional terms and conditions, including a limited warranty, will apply at the time of purchase.

⁵ Projected Calendar life of supercapacitor cells from the date of first operation.

⁶ Shelf life is the life of the module (in years) from the date it is manufactured to the time it is first operated

⁷ CE certification is completed for supercapacitor cells.

Product dimensions are for reference only unless otherwise identified and may change without notice.

For critical applications, please contact your Reseller.